

Electric Motors

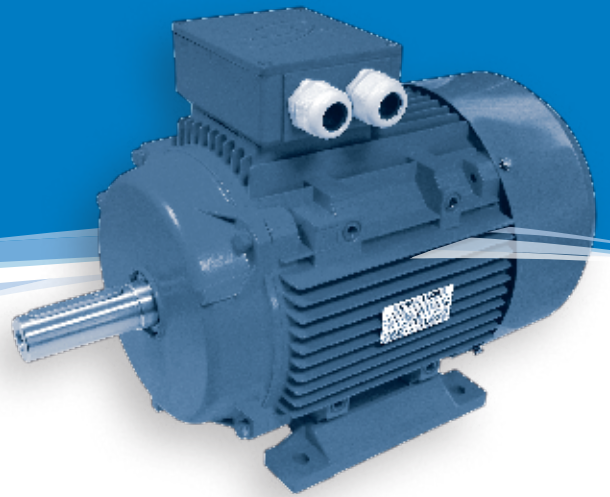

General Information

CHALLENGE series three phase asynchronous AC electric motors, Are totally enclosed fan cooled (**IC-411**) squirrel caged type, With **IP55** enclosure protection, Class F insulation and **SI** continuous Duty/Rating.

The motors are manufactured from high grade die cast aluminium alloy and come with multi-mount detachable feet as standard, which allows for various mounting positions to be achieved.

The temperature ratings are -15° C to +40° degrees C to a maximum altitude of 1000 metres above sea level.

CHALLENGE motors have voltage ratings of 380v / 400v / 415v.

Also they have a rated frequency of 50Hz and 60Hz. Connection is **STAR** up to and including 3kW and from 4kW and above the connection is **DELTA**, allowing for **STAR/DELTA** starting.

Designation

Motor Identification Symbol

CML-801-2

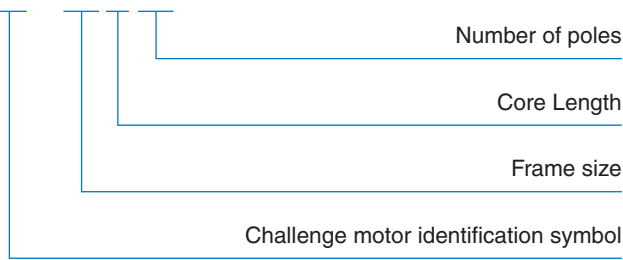

Cooling Method

IC-411

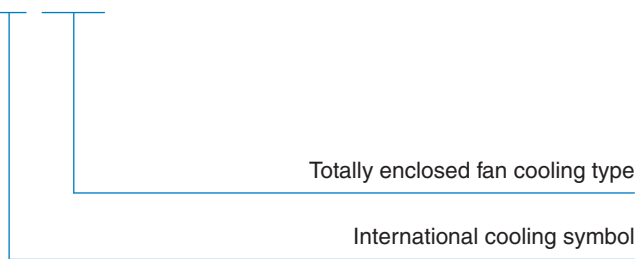

Protection Class

IP-5-5

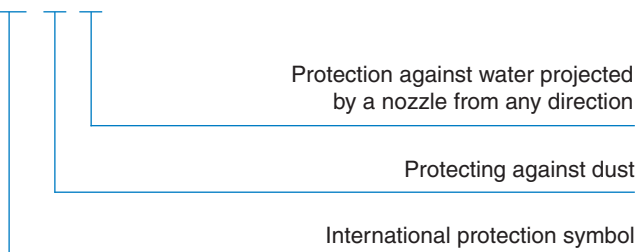

Standards and Regulations



CE Marking

Our three phase induction motors comply with the requirements of the following international standard:

IEC 60034

as well as with the Low Voltage Directive 73/23 (1973), modified by the Directive 93/68 (1993) and the EMC-Directive 89/336.

The above named products comply with the requirements of the EC Directive Machines 89/392. In accordance with this Directive induction motors are components intended solely for integration into other machines. Commissioning is forbidden until conformity of the end product with this Directive is proved!

The  symbol was applied for the first time in 1995.



CEMEP Voluntary Agreement

Motors covered by this agreement are defined as totally enclosed fan cooled (normally IP 54 or IP 55), three phase AC squirrel cage induction motors 1.1 kW to 90 kW, with 2 or 4 poles, rated for 400 V-line, 50 Hz, duty class S1. (Standard design can be interpreted as design N according to EN 60034-12 and HD 231). They are divided in three classes of efficiency levels, defined by two values of full load efficiency per output, designated eff1, eff2.

All motors with standard rating included in this catalogue comply with efficiency class eff2 and bear the corresponding label on the rating plate.

Mechanical Design

Degrees of protection

Degrees of protection for mechanical machines are designated in accordance with IEC 60034-5 by the letters **IP** and two characteristic numerals.

First numeral:	
Protection against contact and ingress of foreign bodies	
IP	Description
0	No special protection
1	Protection against solid foreign bodies larger than 50 mm (Example: inadvertent contact with the hand)
2	Protection against solid foreign bodies larger than 12 mm (Example: inadvertent contact with the fingers)
3	Protection against solid foreign bodies larger than 2.5 mm (Example: Wires, tools)
4	Protection against solid foreign bodies larger than 1 mm (Example: Wires, bands)
5	Protection against dust (harmful deposits of dust)
6	Complete protection against dust. Is not described for electrical machines to IEC 34-5.

Second numeral:	
Protection against ingress of water	
IP	Description
0	No special protection
1	Protection against vertically falling water drops (condensation)
2	Protection against dropping water when inclined by up to 15°
3	Protection against waterspray at up to 60° from vertical
4	Protection against water splashed from any direction
5	Protection against water projected by a nozzle from any direction
6	Protection against heavy seas or water projected in powerful jets
7	Protection when submerged between 0.15 m and 1 m
8	Protection when continuously submerged in water at conditions agreed between the manufacturer and the user

Challenge motors conform to protection IP 55 / IEC 60034-5.

The standard design for horizontal mounting is suitable for indoor and protected outdoor installation, climate group temperature ratings -15° C to +40° C.

For unprotected outdoor installation or severe climatic conditions (moisture category wet, climate group WORLDWIDE, extremely dusty site conditions, aggressive industrial atmosphere, danger of storm rain and coastal climate, danger of attack by termites, etc.), as well as vertical mounting, special protective measures are recommended, such as:

- Protective cowl (for vertical *shaft-down* motors)
- For vertical *shaft-up* motors additional bearing seal and flange drainage
- Special paint finish
- Treatment of winding with protective moisture-proof varnish
- Anti-condensation heating
- Condensation drain holes

The special measures to be applied have to be agreed with the factory once the conditions of installation have been settled.

The corresponding conditions of installation have to be clearly indicated in the order.

Conditions of Installation

Challenge motors are designed for operation at altitudes ≤ 1000 m above sea level and at ambient temperatures of up to 40° C. Exceptions are indicated on the rating plate.

Permissible temperature rises to various standards

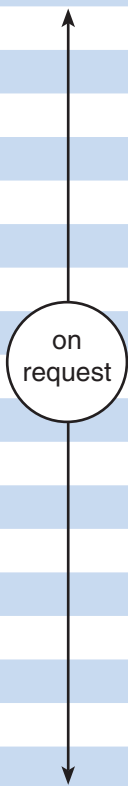
Standard/Regulation	Temperature of coolant	Permissible temperature rise in K (measured by resistance method)		
		Temperature class		
	°C	B	F	H
VDE 0530 part 1	40	80	105	125
International IEC 34-1	40	80	105	125
Britain BS 2613	40	80	105	
Canada CSA	40	80	105	
USA NEMA and ANSI	40	80	105	
Italy CEI	40	80	105	
Sweden SEN	40	80	105	
Norway NEK	40	80	105	
Belgium NBN	40	80	105	
France NF	40	80	105	
Switzerland SEV	40	80	105	
India IS	40	80	-	
Germanischer Lloyd ¹⁾	45	75	90	
American Bureau of Shipping ¹⁾	50	70	95	
Bureau Veritas ¹⁾	45	70	100	
Norske Veritas ¹⁾	45	70	90 ²⁾	
Lloyds Register ¹⁾	45	70	90	
Registro Italiano Navale ¹⁾	45	70	90	
Korean Register ¹⁾	50	70	90	
China Classification Society ¹⁾	45	75	95	

¹⁾ Classification societies for marine motors

²⁾ Only with special approval

Standards and Regulations

The motors comply with the relevant standards and regulations

Title	IEC	EU CENELEC	D DIN/VDE	I CEI/UNEL	GB BS	F NFC	E UNE
Electrical							
General stipulations for electrical machines	60034-1	EN 60034-1	DIN EN 60034-1	CEI EN 60034-1	4999-1 4999-69	51-200 51-111	UNE EN 60034-1
Rotating electrical machines: methods for determining losses and efficiency using tests	60034-2	HD 53 2	DIN EN 60034-2	CEI EN 60034-2	4999-34	51-112	UNE EN 60034-2
Terminal markings and direction of rotation of rotating electrical machines	60034-8	HD 53 8 S4	DIN VDE 0530-8	CEI 2-8	4999-3	51-118	20113-8-96
Starting performance	60034-12	EN 60034-12	DIN EN 6034-12	CEI EN 60034-12	4999-112		UNE EN 60034-12
Standard voltages	60038	HD 472 S1	DIN IEC 60038	CEI 8-6			
Insulating materials	60085		DIN IEC 60085	CEI 15-26			

Mechanical							
Dimensions and output ratings	60072		DIN EN 50347	UNEL 13113			
Mounting dimensions and relationship frame sizes-output ratings, IM B3	60072	HD 231	DIN 42673-1	UNEL 13113	499-10 51-110	51-105 51-104	20106-1/26 1980
Mounting dimensions and relationship frame sizes-output ratings, IM B5	60072	HD 231	DIN 42677-1	UNEL 13117		20106-2-74	
Mounting dimensions and relationship frame sizes-output ratings, IM B14	60072	HD 231	DIN 42677-1	UNEL 13118	499-10 51-110	51-105 51-104	20106-2-1C-80
Cylindrical shaft ends for electric motors	60072	HD 231	DIN 748-3	UNEL 13502	4999-10	51-111	
Degrees of protection	60034-5	EN 60034-5	DIN IE60034-5	CEI IE60034-5	4999-20	EN 60034-5	20111-5
Methods of cooling	60034-6	EN 60034-6	DIN EN60034-6	CEI EN60034-6	4999-21		EN 60034-6
Mounting arrangements	60034-7	EN 60034-7	DIN EN60034-7	CEI EN60034-7	4999-22	51-117	EN 60034-7
Noise limits	60034-9	EN 60034-9	DIN EN60034-9	CEI EN60034-9	4999-51	51-119	EN 60034-9
Mechanical vibration	60034-14	EN 60034-14	DIN EN60034-14	CEI EN60034-14	4999-50	51-111	EN 60034-14
Mounting flanges			DIN 42948	UNEL 13501			
Tolerances of mounting and shaft extensions			DIN 42955	UNEL 13501/ 13502			
Classification of environmental conditions	600721-2-1		DIN IEC 60721-2-1	CEI 75-1			
Mechanical vibration; balancing	ISO 8821		DIN ISO 8821				

Starting Options

Connection

A motor's rated voltage must agree with the power supply line-to-line voltage. Care must therefore be taken to ensure the correct connection to the motor terminals.

Internal connections, Voltages and VF drive selection.

Standard terminal connections for motors 3.0 kW and below is 230 volt delta / 400 volt star. These motors are designed for 400 volt Direct On Line (D.O.L.) starting, when connected in the star configuration. They are also suitable for operation with 230 volt three phase variable frequency drives, when connected in the delta configuration.

Standard terminal connections for motors 4.0 kW and above is 400 volt delta / 690 volt star. These motors are designed for 400 volt Direct On Line (D.O.L.) starting, when connected in the delta configuration. They are also suitable for operation with 400 volt three phase variable frequency drives. Alternatively they can be operated D.O.L. in the star configuration from a 690 volt supply or with a 690 volt variable frequency drive. In this case the drive must be supplied with an output reactor to protect the winding insulation. These motors are also suitable for 400 volt star-delta starting as described below.

Motor connected for D.O.L. starting with bridges in place for star connection (3.0.kW and below)

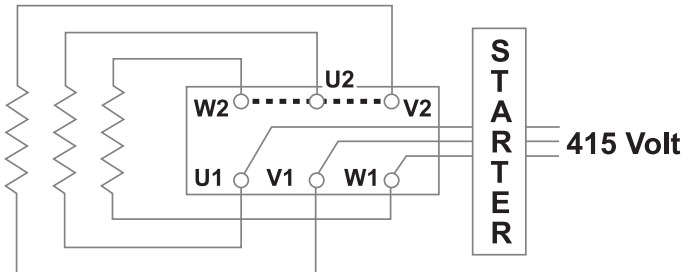

Motor connected for D.O.L. starting with bridges in place for delta connection (4.0.kW and above)

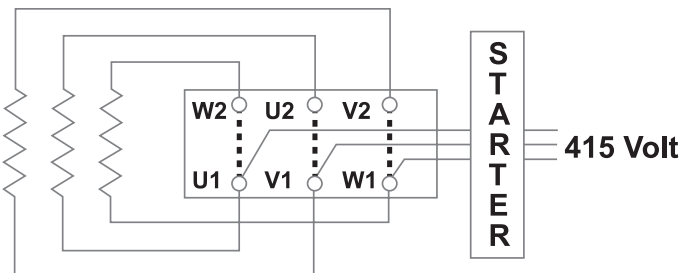

D.O.L. Starters

When an electric motor is started by direct connection to the power supply (D.O.L.), it draws a high current, called the 'starting current', which is approximately equal in magnitude to the locked rotor current I_S . As listed in the performance data locked rotor current can be up to 8 times the rated current I_N of the motor. In circumstances where the motor starts under no load or where high starting torque is not required, it is preferable to reduce the starting current by one of the following means.

Star - Delta starting

Motors 4.0 kW and above are suitable for the star-delta starting method. Through the use of a star-delta starter, the motor terminals are connected in the star configuration during starting, and reconnected to the delta configuration when running. The benefits of this starting method are a significantly lower starting current, to a value about $\frac{1}{3}$ of the D.O.L. starting current, and a corresponding starting torque also reduced to about $\frac{1}{3}$ of its D.O.L. value. It should be noted that a second current surge occurs on changeover to the delta connection. The level of this surge will depend on the speed the motor has reached at the moment of changeover.

Electronic soft starters

Through the use of an electronic soft starter, which controls such parameters as current and voltage, the starting sequence can be totally controlled. The starter can be programmed to limit the amount of starting current and by limiting the rate of the current increase the startup time is extended. Where large heavy loads are to be started it is especially important to extend the startup time.

Variable frequency drives

Variable frequency drives are primarily recognized for their ability to manipulate power from a constant 3 phase 50 Hz power supply converting it to variable frequency power. This enables the speed of motor to be matched to its load in a flexible and energy efficient manner. The only way of producing starting torque equal to full load torque with full load current is by using VF drives. The functionally flexible VF drive is also commonly used to reduce energy consumption on fans, pumps and compressors and offer a simple and repeatable method of changing speeds or flow rates.

Components

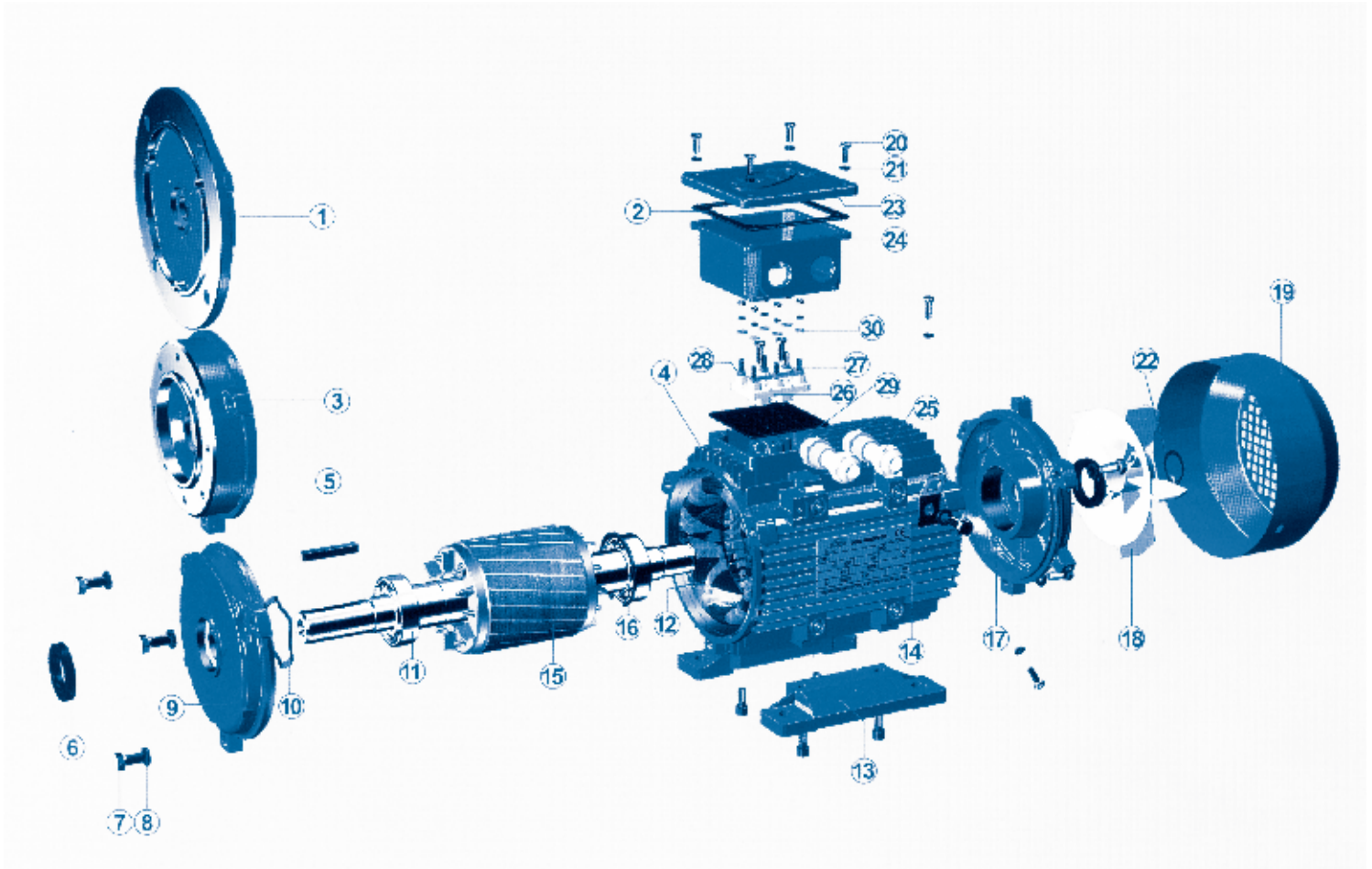

- | | | |
|--------------------|---------------------|-----------------------|
| 1. B5 Flange | 11. Bearing | 21. Washer |
| 2. Gasket | 12. Stator | 22. Fan clamp |
| 3. B14 Flange | 13. Multimount Feet | 23. Terminal box lid |
| 4. Housing | 14. Name plate | 24. Terminal box base |
| 5. Key | 15. Rotor | 25. Cable gland |
| 6. Oil Seal | 16. Circlip | 26. Terminal board |
| 7. Bolt | 17. Rear end shield | 27. Brass lug |
| 8. Spring washer | 18. Fan | 28. Brass nut |
| 9. Front endshield | 19. Fan cowl | 29. Earth mark |
| 10. Wave washer | 20. Screw | 30. Brass washer |

Mounting Arrangements

Mounting arrangements to IEC 60034-7

IM B3 = Foot mounted

IM B3

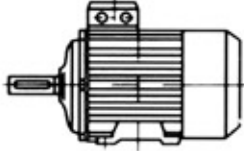

IM B6

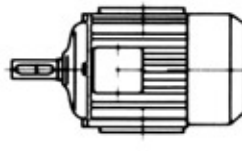

IM B7

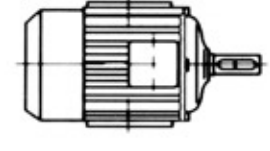

IM B8

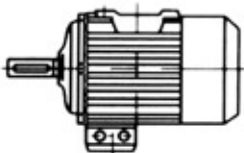

IM V5

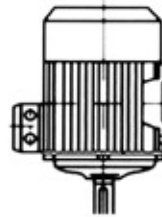

IM V6

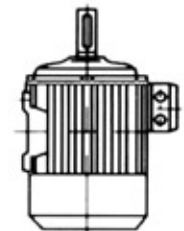

IM B5 = Flange mounted

IM B5

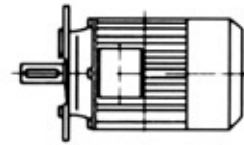

IM V1

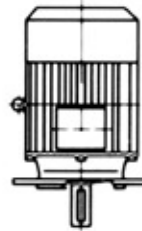

IM V3

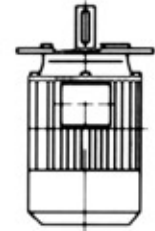

IM B35 = Foot & flange mounted

IM B35

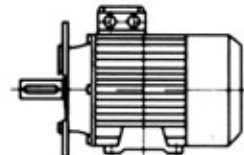

IM V15

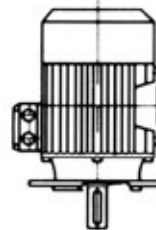

IM V36

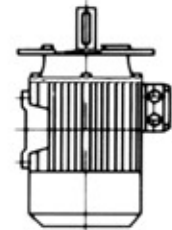

IM B14 = Reduced flange mounted

IM B14

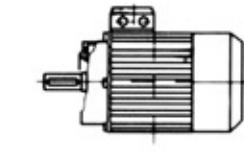

IM V18

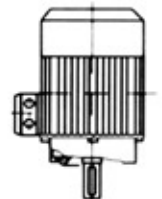

IM V19

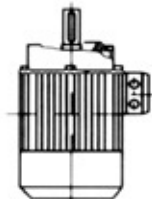

IM B34 = Foot & reduced flange mounted

IM B34

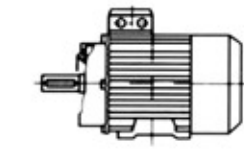

IM V58

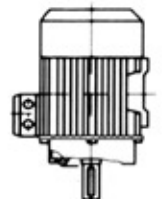

IM V69

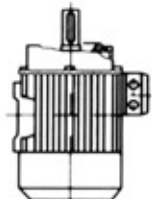

Technical Data EFF 2

Speed 3000 rev/min 2-Pole 50 Hz

Type	Output		Speed rev/min	In A			Efficiency n% 100%	Power Factor Cos 10%	Tn Nm	Ts Tn	Tmax Tn	Is In	Moment (J) kgm²	Noise LwdB(A)	Weight mass/kg
	kW	hp		380V	400V	415V									
CML 561-2	0.09	0.12	2750	0.32	0.30	0.29	62.0	0.70	0.31	2.1	2.2	5.2	0.00018	57	3.6
CML 562-2	0.12	0.18	2750	0.38	0.36	0.72	67.0	0.72	0.41	2.1	2.2	5.2	0.00023	57	3.9
CML 631-2	0.18	0.25	2720	0.53	0.50	0.18	65.0	0.80	0.61	2.2	2.3	5.5	0.00031	58	4.8
CML 632-2	0.25	0.37	2720	0.69	0.66	0.63	68.0	0.81	0.96	2.2	2.3	5.5	0.00060	58	5.1
CML 711-2	0.37	0.50	2740	0.99	0.94	0.91	70.0	0.81	1.26	2.2	2.3	6.1	0.00075	61	6.0
CML 712-2	0.55	0.75	2740	1.40	1.33	1.28	73.0	0.82	1.88	2.2	2.3	6.1	0.00090	61	6.5
CML 801-2	0.75	1.0	2840	1.83	1.73	1.68	75.1	0.83	2.54	2.2	2.3	6.1	0.0012	64	8.7
CML 802-2	1.1	1.5	2840	2.58	2.45	2.37	77.0	0.84	3.72	2.2	2.3	7.0	0.0014	64	9.5
CML 90S-2	1.5	2.0	2840	3.43	3.26	3.14	79.0	0.84	5.14	2.2	2.3	7.0	0.0029	69	11.8
CML 90L-2	2.2	3.0	2840	4.85	4.61	4.44	81.1	0.85	7.40	2.2	2.3	7.0	0.0055	69	13.5
CML 100L-2	3.0	4.0	2860	6.33	6.01	5.79	82.8	0.87	9.95	2.2	2.3	7.5	0.0109	73	21.0
CML 112M-2	4.0	5.5	2880	8.18	7.77	7.49	84.4	0.88	13.22	2.2	2.3	7.5	0.0126	74	28.0
CML 132S1-2	5.5	7.5	2900	11.1	10.5	10.1	85.9	0.88	18.11	2.2	2.3	7.5	0.0377	77	39.0
CML 132S2-2	7.5	10	2900	14.9	14.1	13.6	87.2	0.88	24.70	2.2	2.3	7.5	0.0499	77	44.5
CML 160M1-2	11	15	2930	21.2	20.2	19.4	88.5	0.89	35.85	2.2	2.3	7.5	0.055	83	69.5
CML 160M2-2	15	20	2930	28.6	27.2	26.2	89.5	0.89	48.89	2.2	2.3	7.5	0.075	83	78.0
CML 160L-2	18.5	25	2930	34.6	32.9	31.7	90.2	0.90	60.30	2.2	2.3	7.5	0.124	83	88.5
CML 180M-2	22	30	2940	40.9	38.9	37.5	90.7	0.90	71.46	2.0	2.3	7.5	0.075	89	102.3
CML 200L1-2	30	40	2950	55.4	52.6	50.7	91.5	0.90	97.12	2.0	2.3	7.5	0.124	92	119
CML 200L2-2	37	50	2950	67.7	64.4	62	92.2	0.90	119.78	2.0	2.3	7.5	0.139	92	125

Speed 1500 rev/min 4-Pole 50 Hz

Type	Output		Speed rev/min	In A			Efficiency n% 100%	Power Factor Cos 10%	Tn Nm	Ts Tn	Tmax Tn	Is In	Moment (J) kgm²	Noise LwdB(A)	Weight mass/kg
	kW	hp		380V	400V	415V									
CML 561-4	0.06	0.09	1325	0.28	0.27	0.26	56.0	0.58	0.43	2	2.1	4.0	0.0003	48	3.6
CML 562-4	0.09	0.12	1325	0.39	0.37	0.35	58.0	0.61	0.64	2	2.1	4.0	0.0004	48	3.9
CML 631-4	0.12	0.18	1310	0.44	0.42	0.41	57.0	0.72	0.84	2.1	2.2	4.4	0.0005	48	4.8
CML 632-4	0.18	0.25	1310	0.62	0.59	0.57	60.0	0.73	1.26	2.1	2.2	4.4	0.0006	48	5.1
CML 711-4	0.25	0.37	1330	0.79	0.75	0.72	65.0	0.74	1.73	2.1	2.2	5.2	0.0008	53	6.0
CML 712-4	0.37	0.50	1330	1.12	1.06	1.02	67.0	0.75	2.56	2.1	2.2	5.2	0.0013	53	6.3
CML 801-4	0.55	0.75	1390	1.57	1.49	1.43	71.1	0.75	3.75	2.3	2.3	5.2	0.0018	58	9.4
CML 802-4	0.75	1.0	1390	2.05	1.95	1.88	73.1	0.76	5.11	2.3	2.3	6.0	0.0021	58	10.8
CML 90S-4	1.1	1.5	1390	2.84	2.70	2.60	76.3	0.77	7.50	2.3	2.3	6.0	0.0023	59	12.0
CML 90L-4	1.5	2.0	1390	3.67	3.49	3.36	78.6	0.79	10.23	2.3	2.3	6.0	0.0027	59	13.8
CML 100L1-4	2.2	3.0	1410	5.08	4.83	4.65	81.2	0.81	14.8	2.3	2.3	7.0	0.0054	61	20.8
CML 100L2-4	3.0	4.0	1410	6.72	6.39	6.15	82.7	0.82	20.18	2.3	2.3	7.0	0.0067	61	23.5
CML 112M-4	4.0	5.5	1435	8.79	8.35	8.05	84.3	0.82	26.53	2.3	2.3	7.0	0.0095	62	29.5
CML 132S-4	5.5	7.5	1440	11.7	11.1	10.7	85.8	0.83	36.48	2.3	2.3	7.0	0.0214	69	41.0
CML 132M-4	7.5	10	1440	15.6	14.8	14.3	87.1	0.84	0.74	2.3	2.3	7.0	0.0296	69	47.5
CML 160M-4	11	15	1460	22.5	21.4	20.6	88.5	0.84	0.74	2.3	2.3	7.0	0.0747	72	72.5
CML 160L-4	15	20	1460	30	28.5	27.4	89.5	0.85	0.75	2.3	2.3	7.0	0.0918	72	85.6
CML 180M-4	18.5	25	1470	36.3	34.5	33.2	90.1	0.86	120.19	2.2	2.3	7.5	0.1390	76	101
CML 180L-4	22	30	1470	42.9	40.8	39.3	90.6	0.86	142.93	2.2	2.3	7.5	0.1580	76	112
CML 200L-4	30	40	1470	57.9	55.0	53.0	91.5	0.86	160.96	2.2	2.3	7.2	0.2620	79	122

From frame sizes 180 to 200 the motor can be supplied in a cast iron construction (ref CMC).

Every effort has been taken to ensure that the data listed in this catalogue is correct. Challenge accepts no liability for any inaccuracies or damage caused.

Technical Data EFF 2

Speed 1000 rev/min 6-Pole 50 Hz

Type	Output		Speed rev/min	In A			Efficiency n% 100%	Power Factor Cos 10%	Tn Nm	Ts Tn	Tmax Tn	Is In	Moment (J) kgm²	Noise Lwdb(A)	Weight mass/kg
	kW	hp		380V	400V	415V									
CML 631-6	0.09	0.12	840	0.52	0.49	0.47	44.0	0.60	1.80	1.8	1.9	3.5	0.00025	48	4.8
CML 632-6	0.12	0.18	850	0.63	0.60	0.58	48.0	0.60	2.25	1.8	1.9	3.5	0.0004	48	5.1
CML 711-6	0.18	0.25	850	0.74	0.70	0.68	56.0	0.66	1.91	1.9	2.0	4.0	0.0011	49	6.0
CML 712-6	0.25	0.37	850	0.95	0.90	0.87	59.0	0.68	2.65	1.9	2.0	4.0	0.0014	49	6.3
CML 801-6	0.37	0.5	885	1.30	1.23	1.19	62.0	0.70	3.93	1.9	2.0	4.7	0.0016	51	8.9
CML 802-6	0.55	0.75	885	1.78	1.69	1.63	65.0	0.72	5.84	1.9	2.1	4.7	0.0019	51	10.4
CML 90S-6	0.75	1	910	2.29	2.18	2.10	69.0	0.72	7.87	2.0	2.1	5.5	0.0029	54	12.1
CML 90L-6	1.1	1.5	910	3.18	3.02	2.91	72.1	0.73	11.54	2.0	2.1	5.5	0.0035	54	13.7
CML 100L-6	1.5	2	920	3.99	3.79	3.66	76.1	0.75	15.24	2.0	2.1	5.5	0.0069	58	23.0
CML 112M-6	2.2	3	935	5.55	5.28	5.08	79.2	0.76	22.35	2.1	2.1	6.5	0.0140	62	28.2
CML 132S-6	3	4	960	7.40	7.03	6.77	81.1	0.76	29.84	2.1	2.1	6.5	0.0286	66	40.3
CML 132M1-6	4	5.5	960	9.74	9.25	8.92	82.1	0.76	39.79	2.1	2.1	6.5	0.0357	66	43.0
CML 132M2-6	5.5	7.5	960	12.9	12.3	11.8	84.1	0.77	54.71	2.1	2.1	6.5	0.0449	66	47.2
CML 160M-6	7.5	10	970	17.2	16.3	15.7	86.1	0.77	73.84	2.1	2.1	6.5	0.0810	70	70.6
CML 160L-6	11	15	970	24.5	23.2	22.4	87.6	0.78	108.30	2.1	2.1	6.5	0.1160	70	85.0
CML 180L-6	15	20	970	31.6	30.0	28.9	89.1	0.81	147.68	2.1	2.1	7.0	0.2070	73	105
CML 200L1-6	18.5	25	980	38.5	36.6	35.3	90.1	0.81	182.14	2.1	2.0	7.0	0.3150	76	115
CML 200L2-6	22	30	980	44.7	42.5	40.9	90.1	0.83	216.60	2.1	2.0	7.0	0.3600	76	121

Speed 750 rev/min 8-Pole 50 Hz

Type	Output		Speed rev/min	In A			Efficiency n% 100%	Power Factor Cos 10%	Tn Nm	Ts Tn	Tmax Tn	Is In	Moment (J) kgm²	Noise Lwdb(A)	Weight mass/kg
	kW	hp		380V	400V	415V									
CML 711-8	0.09	0.12	600	0.60	0.57	0.55	40.0	0.57	1.95	1.8	1.9	2.8	0.0008	48	6.0
CML 712-8	0.12	0.18	600	0.71	0.70	0.65	45.0	0.57	2.16	1.8	1.9	2.8	0.0010	48	6.3
CML 801-8	0.18	0.25	645	0.88	0.84	0.80	51.0	0.61	2.5	1.8	1.9	3.3	0.0025	48	8.9
CML 802-8	0.25	0.37	645	1.15	1.10	1.06	54.0	0.61	3.5	1.8	1.9	3.3	0.0030	48	10.4
CML 90S-8	0.37	0.5	670	1.49	1.41	1.36	62.0	0.61	5.1	1.8	1.9	4.0	0.0051	53	12.1
CML 90L-8	0.55	0.75	670	2.17	2.07	1.99	63.0	0.61	7.6	1.8	2.0	4.0	0.0065	53	13.7
CML 100L1-8	0.75	1	680	2.40	2.28	2.19	71.0	0.67	10.2	1.8	2.0	4.0	0.0095	56	23.0
CML 100L2-8	1.1	1.5	680	3.32	3.15	3.04	73.0	0.69	15.0	1.8	2.0	5.0	0.0110	56	25.1
CML 112M-8	1.5	2	690	4.40	4.18	4.03	75.0	0.69	20.5	1.8	2.0	5.0	0.0245	59	28.2
CML 132S-8	2.2	3	705	6.04	5.73	5.53	78.0	0.71	19.6	1.8	2.0	6.0	0.0314	61	40.3
CML 132M-8	3	4	705	7.90	7.51	7.24	79.0	0.73	40.4	1.8	2.0	6.0	0.0395	61	45.0
CML 160M1-8	4	5.5	720	10.30	9.76	9.41	81.0	0.73	53.1	1.9	2.0	6.0	0.0753	65	68.5
CML 160M2-8	5.5	7.5	720	13.60	12.90	12.50	83.0	0.74	72.6	2.0	2.0	6.0	0.0931	65	76.0
CML 160L-8	7.5	10	720	17.80	16.90	16.30	85.5	0.75	99.5	2.0	2.0	6.0	0.1260	65	86.2
CML 180L-8	11	15	730	25.10	23.9	23.00	87.5	0.76	143.90	2.0	2.0	6.0	0.2030	70	101
CML 200L-8	15	20	730	34.10	32.4	31.20	88.0	0.76	196.23	2.0	2.0	6.6	0.3990	73	120

From frame sizes 180 to 200 the motor can be supplied in a cast iron construction (ref CMC).

Cable Entry and Bearing Sizes

Cable Entry

Classified number	Frame size	Max .fl.amps	Entry size
1	63-80	2.6	1 x M20x1.5
2	90-100	6.8	1 x M20x1.5
3	112-132	15.4	2 x M32x1 .5
4	160-180	42.5	2 x M40x1.5
5	200	84.2	2 x M50x1.5

Bearing Size

Frame size	Poles	Drive End	Non-Drive End
56	2 to 4	6201 2RS-C3 (6201 ZZ-C3)	6201 2RS-C3 (6201 ZZ-C3)
63	2 to 6	6201 2RS-C3 (6201 ZZ-C3)	6201 2RS-C3 (6201 ZZ-C3)
71	2 to 8	6202 2RS-C3 (6202 ZZ-C3)	6202 2RS-C3 (6202 ZZ-C3)
80	2 to 8	6204 2RS-C3 (6204 ZZ-C3)	6204 2RS-C3 (6204 ZZ-C3)
90	2 to 8	6205 2RS-C3 (6205 ZZ-C3)	6205 2RS-C3 (6205 ZZ-C3)
100	2 to 8	6206 2RS-C3 (6206 ZZ-C3)	6206 2RS-C3 (6206 ZZ-C3)
112	2 to 8	6206 2RS-C3 (6206 ZZ-C3)	6206 2RS-C3 (6206 ZZ-C3)
132	2 to 8	6208 2RS-C3 (6208 ZZ-C3)	6208 2RS-C3 (6208 ZZ-C3)
160	2 to 8	6309 2RS-C3 (6309 ZZ-C3)	6309 2RS-C3 (6309 ZZ-C3)
180	2 to 8	6311 ZZ-C3	6311 ZZC3
200	2 to 8	6312 ZZ-C3	6312 ZZC3

Mounting and Overall Dimensions

IM B3 Foot mounted frame size 56 to 200

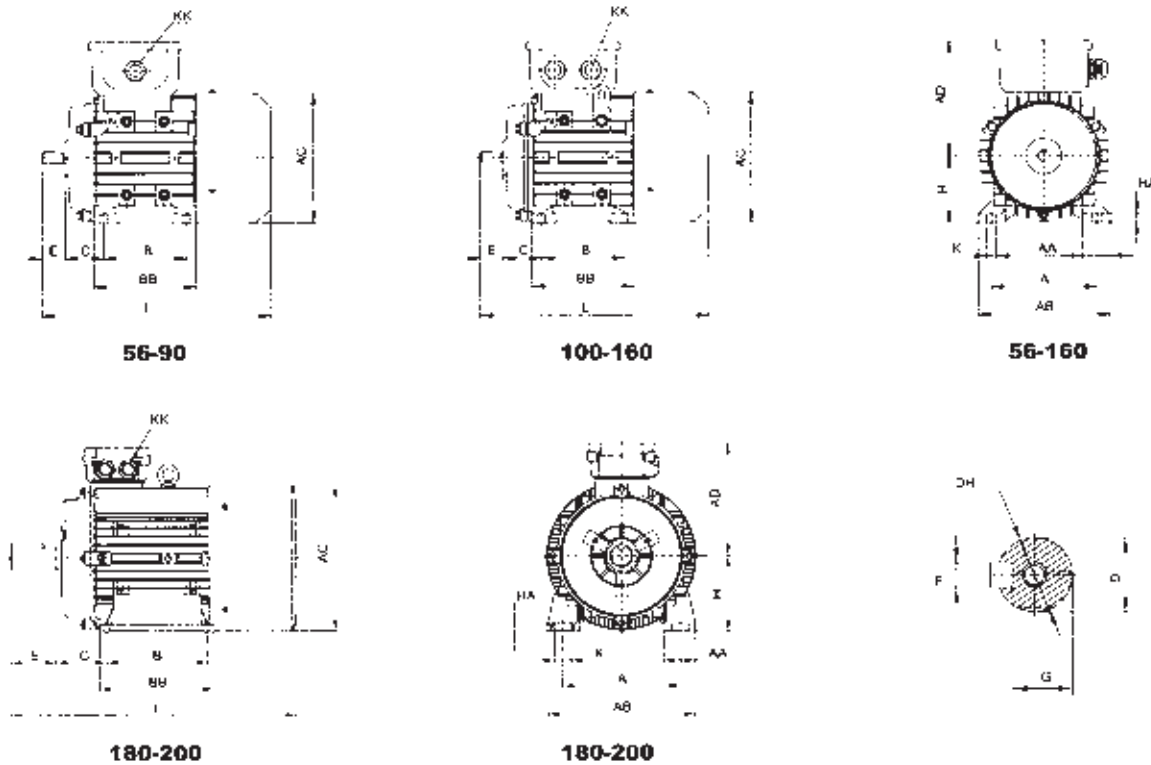

Frame Size	Mounting Dimensions																		Overall Dimensions L
	A	AA	AB	BB	HA	AC	AD	B	C	D	DH	E	F	G	H	K	KK		
	Metric		PG																
56	90	23	115	88	7	110	100	71	36	9	M4x12	20	3	7.2	56	5.8	1-M20X1.5	1-PG11	199
63	100	24	135	100	7	130	111	80	40	11	M4x12	23	4	8.5	63	7.0	1-M20X1.5	1-PG11	217
71	112	26	150	110	8	145	118	90	45	14	M5x12	30	5	11	71	7.0	1-M20X1.5	1-PG11	245
80	125	35	165	125	9	175	134	100	50	19	M6x16	40	6	15.5	80	10.0	1-M25X1.5	1-PG16	287
90S	140	37	180	125	10	195	140	100	56	24	M8x19	50	8	20.0	90	10.0	1-M25X1.5	1-PG16	315
90L	140	37	180	150	10	195	140	125	56	24	M8x19	50	8	20.0	90	10.0	1-M25X1.5	1-PG16	340
100L	160	40	205	172	11	215	160	140	63	28	M10x22	60	8	24.0	100	12.0	1-M32X1.5	1-PG21	385
112M	190	41	230	181	12	240	178	140	70	28	M10x22	60	8	24.0	112	12.0	2-M32X1.5	2-PG21	400
132S	216	51	270	186	15	275	206	140	89	38	M12x28	80	10	33.0	132	12.0	2-M32X1.5	2-PG21	483
132M	216	51	270	224	15	275	206	178	89	38	M12x28	80	10	33.0	132	12.0	2-M32X1.5	2-PG21	510
160M	254	55	320	260	18	330	255	210	108	42	M16x36	110	12	37.0	160	15.0	2-M40X1.5	2-PG29	615
160L	254	55	320	304	18	330	255	254	108	42	M16x36	110	12	37.0	160	16.0	2-M40X1.5	2-PG29	670
180M	279	75	350	315	18	355	272	241	121	48	M16x36	110	14	42.5	180	15	2-M32x1.5	2-PG29	765
180L	279	75	350	315	18	355	272	279	121	48	M16x36	110	14	42.5	180	15	2-M32x1.5	2-PG29	765
200L	318	100	398	355	24	355	272	305	133	55	M20x42	110	16	49	200	19	2-M32x1.5	2-PG36	790

All dimensions in millimetres unless otherwise stated. Every effort has been taken to ensure that the data listed in this catalogue is correct. Challenge accepts no liability for any inaccuracies or damage caused.

Mounting and Overall Dimensions

IM B5 Flange mounted frame size 56 to 200

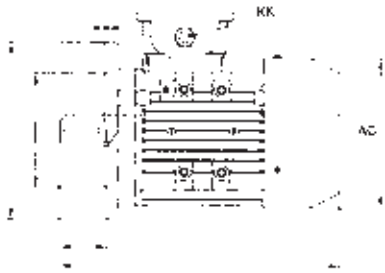

56-90

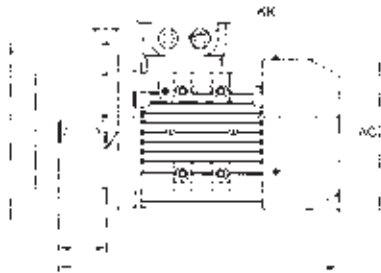

100-160

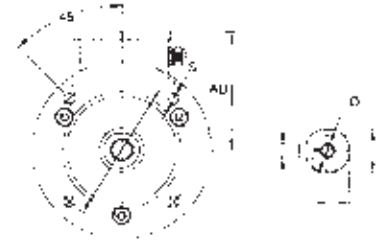

56-160

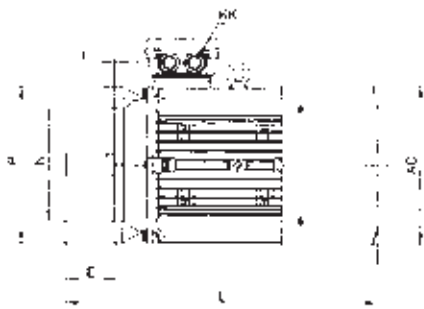

180-200

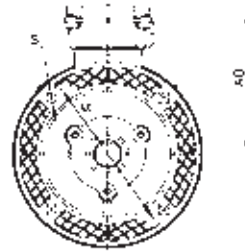

180-200

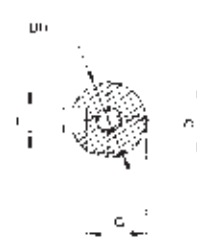

Frame Size	Mounting Dimensions													Overall Dimensions						
	HA	AC	AD	B	C	D	DH	E	F	G	H	K	KK		L	M	N	P	S	T
													Metric	PG						
56	7	110	100	71	36	9	M4x12	20	3	7.2	56	5.8	1-M20x1.5	1-PG11	199	100	80	120	7	3.0
63	7	130	111	80	40	11	M4x12	23	4	8.5	63	7.0	1-M20x1.5	1-PG11	217	115	95	140	10	3.0
71	8	145	118	90	45	14	M5x12	30	5	11	71	7.0	1-M20x1.5	1-PG11	245	130	110	160	12	3.5
80	9	175	134	100	50	19	M6x16	40	6	15.5	80	10.0	1-M25x1.5	1-PG16	287	165	130	200	12	3.5
90S	10	195	140	100	56	24	M8x19	50	8	20.0	90	10.0	1-M25x1.5	1-PG16	315	165	130	200	12	3.5
90L	10	195	140	125	56	24	M8x19	50	8	20.0	90	10.0	1-M25x1.5	1-PG16	340	165	130	200	12	3.5
100L	11	215	160	140	63	28	M10x22	60	8	24.0	100	12.0	1-M32x1.5	1-PG21	385	215	180	250	15	4.0
112M	12	240	178	140	70	28	M10x22	60	8	24.0	112	12.0	2-M32x1.5	2-PG21	400	215	180	250	15	4.0
132S	15	275	206	140	89	38	M12x28	80	10	33.0	132	12.0	2-M32x1.5	2-PG21	483	265	230	300	15	4.0
132M	15	275	206	178	89	38	M12x28	80	10	33.0	132	12.0	2-M32x1.5	2-PG21	510	265	230	300	15	4.0
160M	18	330	255	210	108	42	M16x36	110	12	37.0	160	15.0	2-M40x1.5	2-PG29	615	300	250	350	19	5.0
160L	18	330	255	254	108	42	M16x36	110	12	37.0	160	16.0	2-M40x1.5	2-PG29	670	300	250	350	19	5.0
180M	18	355	272	241	121	48	M16x36	110	14	42.5	180	15	2-M32x1.5	2-PG29	765	300	250	350	19	5.0
180L	18	355	272	279	121	48	M16x36	110	14	42.5	180	15	2-M32x1.5	2-PG29	765	300	250	350	19	5.0
200L	24	355	272	305	133	55	M20x42	110	16	49	200	19	2-M32x1.5	2-PG36	790	350	300	400	19	5.0

Every effort has been taken to ensure that the data listed in this catalogue is correct. Challenge accepts no liability for any inaccuracies or damage caused. All dimensions in millimetres unless otherwise stated.

Mounting and Overall Dimensions

IM B35 Foot and flange mounted frame size 56 to 200

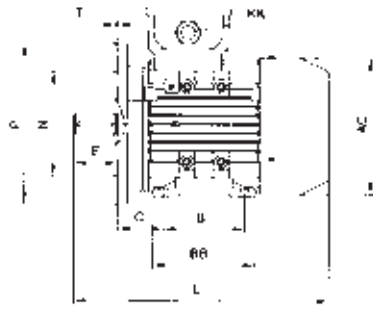

56-90

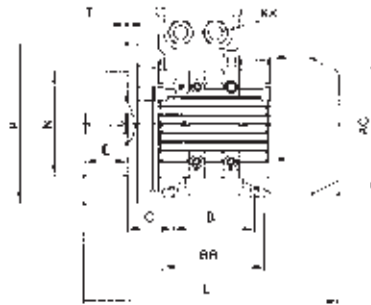

100-160

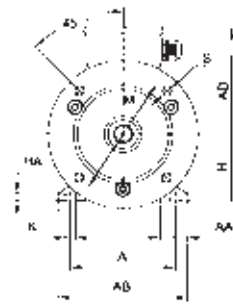

56-160

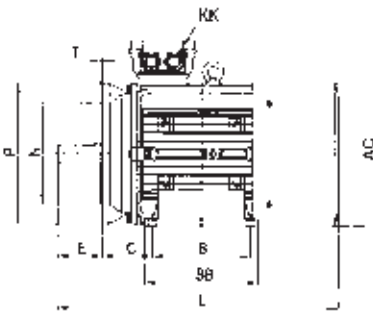

180-200

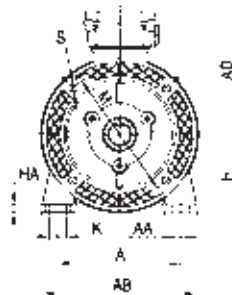

180-200

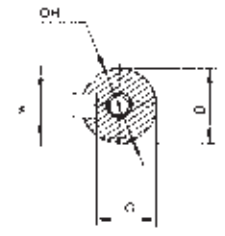

Frame Size	Mounting Dimensions																	Overall Dimensions						
	A	AA	AB	BB	HA	AC	AD	B	C	D	DH	E	F	G	H	K	KK		L	M	N	P	S	T
	Metric		PG																					
56	90	23	115	88	7	110	100	71	36	9	M4X12	20	3	7.2	56	5.8	1-M20X1.5	1-PG11	199	100	80	120	7	3.0
63	100	24	135	100	7	130	111	80	40	11	M4X12	23	4	8.5	63	7.0	1-M20X1.5	1-PG11	217	115	95	140	10	3.0
71	112	26	150	110	8	145	118	90	45	14	M5X12	30	5	11	71	7.0	1-M20X1.5	1-PG11	245	130	110	160	12	3.5
80	125	35	165	125	9	175	134	100	50	19	M6X16	40	6	15.5	80	10.0	1-M25X1.5	1-PG16	287	165	130	200	12	3.5
90S	140	37	180	125	10	195	140	100	56	24	M8X19	50	8	20.0	90	10.0	1-M25X1.5	1-PG16	315	165	130	200	12	3.5
90L	140	37	180	150	10	195	140	125	56	24	M8X19	50	8	20.0	90	10.0	1-M25X1.5	1-PG16	340	165	130	200	12	3.5
100L	160	40	205	172	11	215	160	140	63	28	M10X22	60	8	24.0	100	12.0	1-M32X1.5	1-PG21	385	215	180	250	15	4.0
112M	190	41	230	181	12	240	178	140	70	28	M10X22	60	8	24.0	112	12.0	2-M32X1.5	2-PG21	400	215	180	250	15	4.0
132S	216	51	270	186	15	275	206	140	89	38	M12X28	80	10	33.0	132	12.0	2-M32X1.5	2-PG21	483	265	230	300	15	4.0
132M	216	51	270	224	15	275	206	178	89	38	M12X28	80	10	33.0	132	12.0	2-M32X1.5	2-PG21	510	265	230	300	15	4.0
160M	254	55	320	260	18	330	255	210	108	42	M16X36	110	12	37.0	160	15.0	2-M40X1.5	2-PG29	615	300	250	350	19	5.0
160L	254	55	320	304	18	330	255	254	108	42	M16X36	110	12	37.0	160	16.0	2-M40X1.5	2-PG29	670	300	250	350	19	5.0
180M	279	75	350	315	18	355	272	241	121	48	M16X36	110	14	42.5	180	15	2-M32x1.5	2-PG29	765	300	250	350	19	5.0
180L	279	75	350	315	18	355	272	279	121	48	M16X36	110	14	42.5	180	15	2-M32x1.5	2-PG29	765	300	250	350	19	5.0
200L	318	100	398	355	24	355	272	305	133	55	M20X42	110	16	49	200	19	2-M32X1.5	2-PG36	790	350	300	400	19	5.0

All dimensions in millimetres unless otherwise stated. Every effort has been taken to ensure that the data listed in this catalogue is correct. Challenge accepts no liability for any inaccuracies or damage caused.

Mounting and Overall Dimensions

IM B14A Reduced flange mounted frame size 56 to 160

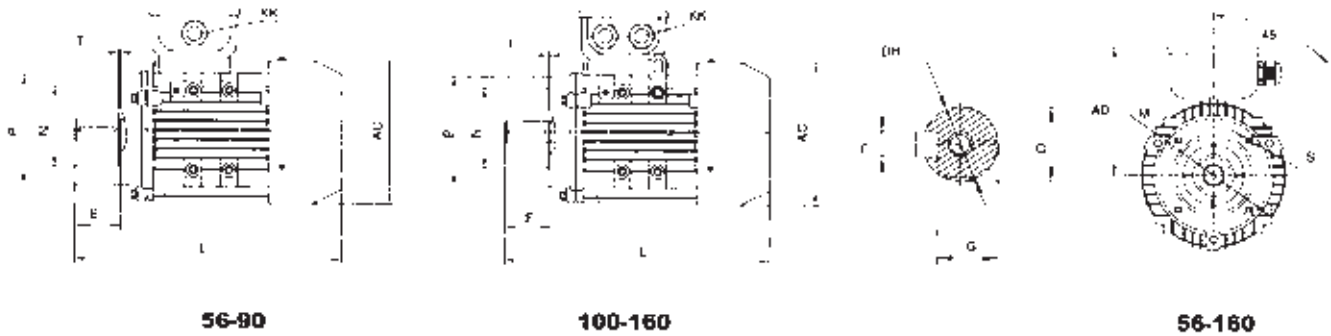

Frame Size	Mounting Dimensions									Overall Dimensions					
	AC	AD	D	DH	E	F	G	KK		L	M	N	P	S	T
								Metric	PG						
56	110	100	9	M4x12	20	3	7.2	1-M20x1.5	1-PG11	199	65	50	80	M5	2.5
63	130	111	11	M4x12	23	4	8.5	1-M20x1.5	1-PG11	217	75	60	90	M5	2.5
71	145	118	14	M5x12	30	5	11.0	1-M20x1.5	1-PG11	245	85	70	105	M6	2.5
80	175	134	19	M6x16	40	6	15.5	1-M25x1.5	1-PG16	297	100	80	120	M6	3.0
90S	195	140	24	M8x19	50	8	20.0	1-M25x1.5	1-PG16	315	115	95	140	M8	3.0
90L	195	140	24	M8x19	50	8	20.0	1-M25x1.5	1-PG16	340	115	95	140	M8	3.0
100L	215	160	28	M10x22	60	8	24.0	1-M32x1.5	1-PG21	385	130	110	160	M8	3.5
112M	240	178	28	M10x22	60	8	24.0	2-M32x1.5	2-PG21	400	130	110	160	M8	3.5
132S	275	206	38	M12x28	80	10	33.0	2-M32x1.5	2-PG21	483	165	130	200	M10	3.5
132M	275	206	38	M12x28	80	10	33.0	2-M32x1.5	2-PG21	510	165	130	200	M10	3.5
160M	330	255	42	M16x36	110	12	37.0	2-M40x1.5	2-PG29	615	215	180	250	M12	4.0
160L	330	255	42	M16x36	110	12	37.0	2-M40x1.5	2-PG29	670	215	180	250	M12	4.0

Mounting and Overall Dimensions

IM B3 B14A Reduced flange and foot mounted frame size 56 to 160

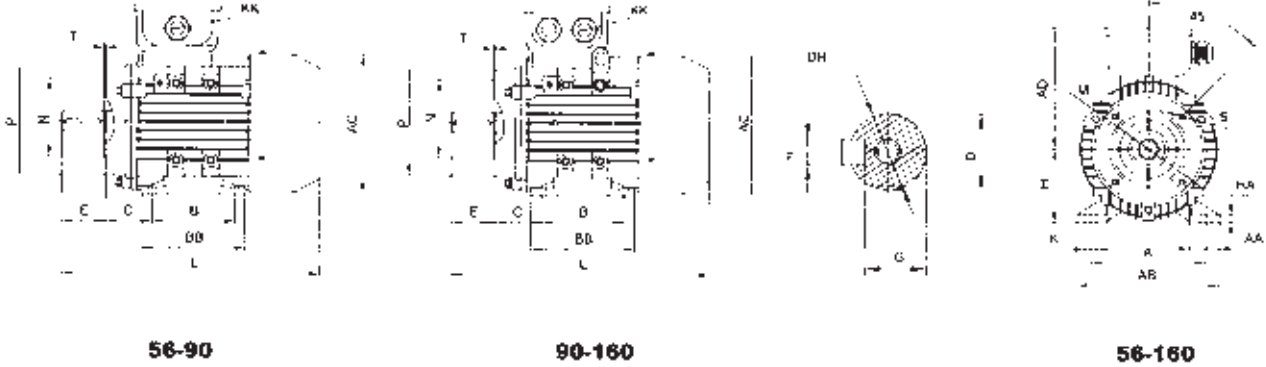

Frame Size	Mounting Dimensions									Overall Dimensions					
	AC	AD	D	DH	E	F	G	KK		L	M	N	P	S	T
								Metric	PG						
56	110	100	9	M4x12	20	3	7.2	1-M20x1.5	1-PG11	199	65	50	80	M5	2.5
63	130	111	11	M4x12	23	4	8.5	1-M20x1.5	1-PG11	217	75	60	90	M5	2.5
71	145	118	14	M5x12	30	5	11.0	1-M20x1.5	1-PG11	245	85	70	105	M6	2.5
80	175	134	19	M6x16	40	6	15.5	1-M25x1.5	1-PG16	297	100	80	120	M6	3.0
90S	195	140	24	M8x19	50	8	20.0	1-M25x1.5	1-PG16	315	115	95	140	M8	3.0
90L	195	140	24	M8x19	50	8	20.0	1-M25x1.5	1-PG16	340	115	95	140	M8	3.0
100L	215	160	28	M10x22	60	8	24.0	1-M32x1.5	1-PG21	385	130	110	160	M8	3.5
112M	240	178	28	M10x22	60	8	24.0	2-M32x1.5	2-PG21	400	130	110	160	M8	3.5
132S	275	206	38	M12x28	80	10	33.0	2-M32x1.5	2-PG21	483	165	130	200	M10	3.5
132M	275	206	38	M12x28	80	10	33.0	2-M32x1.5	2-PG21	510	165	130	200	M10	3.5
160M	330	255	42	M16x36	110	12	37.0	2-M40x1.5	2-PG29	615	215	180	250	M12	4.0
160L	330	255	42	M16x36	110	12	37.0	2-M40x1.5	2-PG29	670	215	180	250	M12	4.0

All dimensions in millimetres unless otherwise stated. Every effort has been taken to ensure that the data listed in this catalogue is correct. Challenge accepts no liability for any inaccuracies or damage caused.

Single Phase General Information

CHALLENGE series single phase AC electric motors, Are totally enclosed fan cooled (**IC-411**) squirrel caged type, With **IP55** enclosure protection, Class F insulation and **S1** continuous Duty/ Rating.

The motors are manufactured from high grade die cast aluminium alloy with a terminal box constructed of engineering grade plastic and come with multi-mount detachable feet as standard, which allows for various mounting positions to be achieved.

The temperature ratings are -15° C to +40° degrees C to a maximum altitude of 1000 metres above sea level.

CHALLENGE motors have voltage ratings of: 110v / 220v / 230v / 240v.

Also they have a rated frequency of 50Hz and 60Hz.

Designation

Motor Identification Symbol

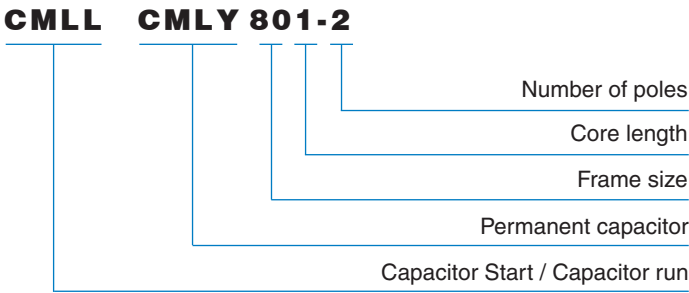

Cooling Method



Protection Class

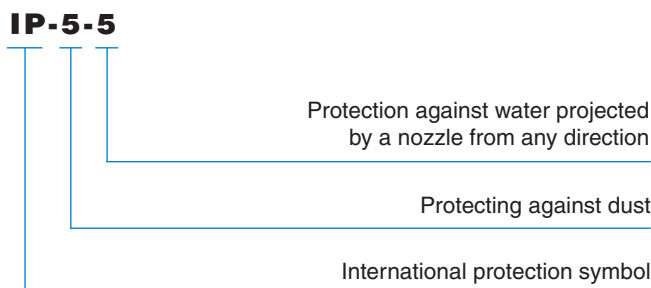

Standards and Regulations



CE Marking

Our single phase induction motors comply with the requirements of the following international standard:

IEC 60034

as well as with the Low Voltage Directive 73/23 (1973), modified by the Directive 93/68 (1993) and the EMC-Directive 89/336.

The above named products comply with the requirements of the EC Directive Machines 89/392. In accordance with this Directive induction motors are components intended solely for integration into other machines. Commissioning is forbidden until conformity of the end product with this Directive is proved!

The  symbol was applied for the first time in 1995.

Technical Data Single Phase

CMLY Single phase motors with permanent capacitors

Type	Output		Current (A)	Speed rev/min	Efficiency n% 100%	Power Factor Cos 10%	Ts Tn	Tmax Tn	Is In	Capacity (UF)	Moment (J) kgm ²	Weight mass/kg
	kW	hp										
CMLY561-2	0.09	0.12	0.7	2720	55	0.90	0.60	1.7	3.6	10	0.00010	3.4
CMLY562-2	0.12	0.18	1.0	2720	55	0.90	0.60	1.7	3.6	14	0.00012	3.7
CMLY631-2	0.18	0.25	1.47	2760	60	0.92	0.66	1.7	3.7	10	0.000150	4.1
CMLY632-2	0.25	0.37	1.91	2760	60	0.92	0.66	1.7	3.7	10	0.000163	4.5
CMLY711-2	0.37	0.5	3.12	2800	65	0.92	0.71	1.7	3.7	16	0.000350	6.4
CMLY712-2	0.55	0.75	3.63	2800	65	0.92	0.74	1.7	3.9	20	0.000460	6.6
CMLY801-2	0.75	1	5.50	2810	67	0.92	0.75	1.7	3.9	25	0.000970	8.3
CMLY802-2	1.1	1.5	7.52	2820	67	0.95	0.77	1.7	4.3	30	0.001090	9.1
CMLY90S-2	1.5	2	10.75	2840	72	0.95	0.78	1.7	4.8	40	0.002690	13.5
CMLY90L-2	2.2	3	13.10	2840	73	0.95	0.80	1.7	4.8	50	0.003080	15.6
CMLY100L-2	3	4	16.8	2800	79	0.99	0.80	1.9	4.8	60	0.01260	20.0
CMLY561-4	0.06	0.08	0.65	1360	55	0.90	0.61	1.7	3.1	5	0.00030	3.4
CMLY562-4	0.09	0.12	0.85	1360	55	0.90	0.61	1.7	3.1	6.3	0.00040	3.6
CMLY63M	0.12	0.18	1.40	1340	60	0.9	0.68	1.7	3.2	8	0.000170	4.1
CMLY632-4	0.18	0.25	1.52	1340	60	0.9	0.68	1.7	3.3	10	0.000230	4.6
CMLY711-4	0.25	0.37	2.2	1370	62	0.92	0.73	1.7	3.4	12.5	0.000400	6.3
CMLY712-4	0.37	0.5	2.80	1370	62	0.92	0.75	1.7	3.4	12.5	0.000570	7.3
CMLY801-4	0.55	0.75	4.51	1400	63	0.92	0.78	1.7	3.5	20	0.001400	9.8
CMLY802-4	0.75	1	5.2	1400	65	0.92	0.78	1.7	3.7	25	0.001600	10.5
CMLY90S-4	1.1	1.5	8.85	1410	70	0.95	0.80	1.7	4	30	0.002830	13.6
CMLY90L-4	1.5	2	9.51	1410	71	0.95	0.80	1.7	4.6	40	0.003590	16.8
CMLY100L1-4	2.2	3	14.0	1420	79	0.85	0.82	1.9	4.8	50	0.00540	20.0
CMLY100L2-4	3	4	16.7	1420	79	0.98	0.83	1.9	4.8	60	0.00670	21.5

CMLL Single phase motors with capacitor start - capacitor run

Type	Output		Current (A)	Speed rev/min	Efficiency n% 100%	Power Factor Cos 10%	Ts Tn	Tmax Tn	Is In	Moment (J) kgm ²	Weight mass/kg
	kW	hp									
CMLL711-2	0.37	0.50	2.73	2760	69	0.92	1.8	1.8	5.8	0.000610	6.5
CMLL712-2	0.55	0.75	3.88	2780	72	0.92	1.8	1.8	5.4	0.000720	7.2
CMLL801-2	0.75	1	5.15	2800	75	0.92	1.8	1.7	5.7	0.000970	8.5
CMLL802-2	1.1	1.5	7.02	2800	78	0.95	1.8	1.7	5.6	0.001100	9.5
CMLL90S-2	1.5	2	9.40	2800	78	0.95	1.7	1.7	6.0	0.002960	13.2
CMLL90L-2	2.2	3	13.70	2800	82	0.95	1.7	1.7	6.2	0.003240	14.5
CMLL100L1-2	3.0	4	18.40	2820	83	0.95	1.7	1.7	6.4	0.003930	21.0
CMLL711-4	0.25	0.37	1.99	1360	65	0.92	1.8	1.8	6.0	0.000910	6.7
CMLL712-4	0.37	0.55	2.81	1370	67	0.92	1.8	1.8	5.7	0.000100	7.4
CMLL801-4	0.55	0.75	4.00	1400	70	0.92	1.8	1.7	5.4	0.001700	8.8
CMLL802-4	0.75	1.0	5.30	1400	71	0.92	1.8	1.7	5.5	0.001960	10.0
CMLL90S-4	1.1	1.5	7.20	1400	76	0.95	1.7	1.7	5.7	0.003050	13.5
CMLL90L-4	1.5	2	9.57	1400	78	0.95	1.7	1.7	6.0	0.003890	16.6
CMLL100L1-4	2.2	3	13.85	1410	80	0.95	1.7	1.7	6.1	0.005100	24.0
CMLL100L1-4	3	4	18.17	1420	83	0.95	1.7	1.7	6.4	0.006300	28.2

Every effort has been taken to ensure that the data listed in this catalogue is correct. Challenge accepts no liability for any inaccuracies or damage caused.

Mounting and Overall Dimensions

IM B3 frame size 56 to 100

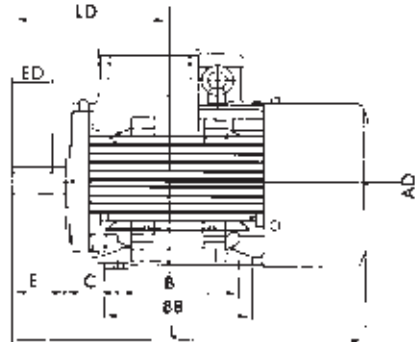
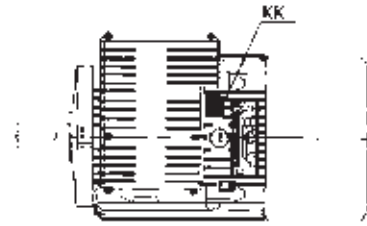
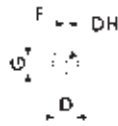
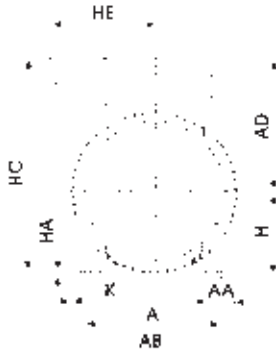

IM B5/V1 frame size 56 to 100

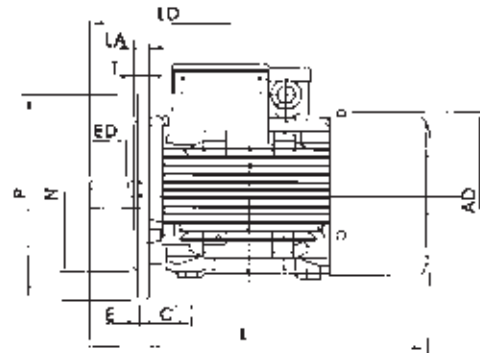
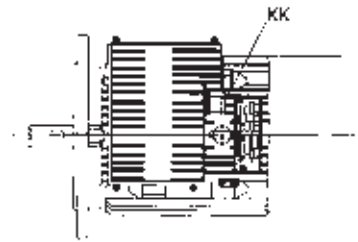
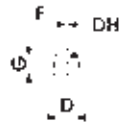
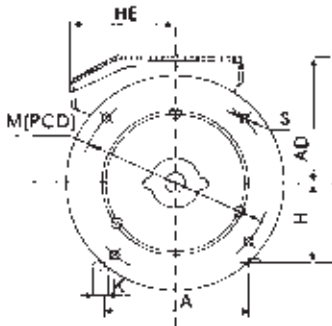

CMLY Single phase motors with permanent capacitors

Frame	A	AA	AB	AC	AD	B	BB	C	D	DH	E	F	G	H	K	KK	L	M	N	P	S	T
56 63	100	24	135	130	115	80	115	40	11	M4 X 12	23	4	8.5	63	7	1-M20 X 1.5	217	115	95	140	10	3.0
71	112	26	150	145	120	90	125	45	14	M5 X 12	30	5	11.0	71	7	1-M20 X 1.5	245	130	130	160	10	3.5
80	125	35	165	175	145	100	135	50	19	M6 X 16	40	6	15.5	80	10	1-M25 X 1.5	300	165	165	200	12	3.5
90S	140	37	180	195	155	100	140	56	24	M8 X 19	50	8	20.0	90	10	1-M25 X 1.5	320	165	165	200	12	3.5
90L	140	37	180	195	155	125	165	56	24	M8 X 19	50	8	20.0	90	10	1-M25 X 1.5	350	165	165	200	12	3.5
100L	160	40	205	215	180	140	185	63	28	M10 X 22	60	8	24.0	100	12	1-M25 X 1.5	385	215	215	250	15	4.0

Mounting and Overall Dimensions

IM B3 frame size 71 to 100

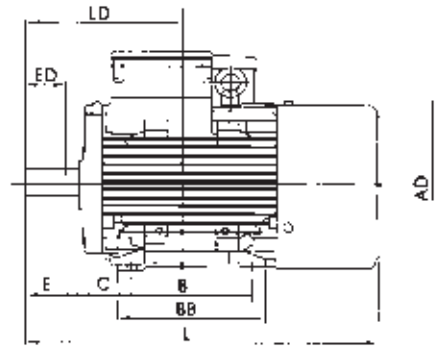
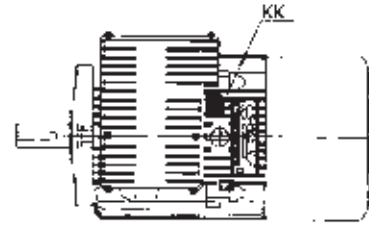
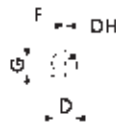

IM B5/V1 frame size 71 to 100

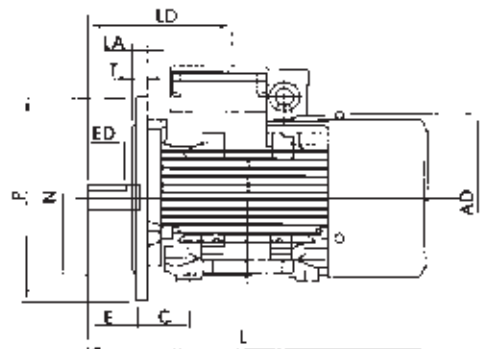
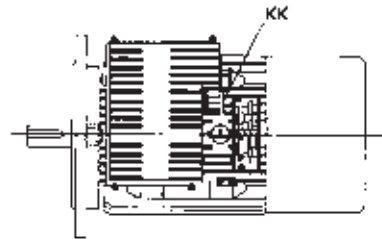
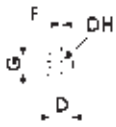
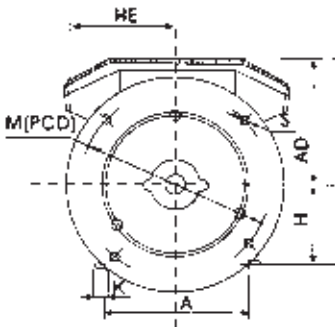

CMLL Single phase motors with capacitor start - capacitor run

Frame	A	AA	AB	AC	AD	B	BB	C	D	DH	E	F	G	H	K	KK	L	M	N	P	S	T
71	112	26	150	145	120	90	125	45	14	M5 X 12	30	5	11.0	71	7	1-M20 X 1.5	245	130	110	160	10	3.5
80	125	35	165	175	145	100	135	50	19	M6 X 16	40	6	15.5	80	10	1-M25 X 1.5	300	165	130	200	12	3.5
90S	140	37	180	195	155	100	140	56	24	M8 X 19	50	8	20.0	90	10	1-M25 X 1.5	320	165	130	200	12	3.5
90L	140	37	180	195	155	125	165	56	24	M8 X 19	50	8	20.0	90	10	1-M25 X 1.5	350	165	130	200	12	3.5
100	160	40	205	215	180	140	185	63	28	M10 X 22	60	8	24.0	100	12	1-M25 X 1.5	385	215	180	250	15	4.0

All dimensions in millimetres unless otherwise stated. Every effort has been taken to ensure that the data listed in this catalogue is correct. Challenge accepts no liability for any inaccuracies or damage caused.

Single Phase Connections

Connection

A motor's rated voltage must agree with the power supply line-to-line voltage. Care must therefore be taken to ensure the correct connection to the motor terminals.

CMLY Series

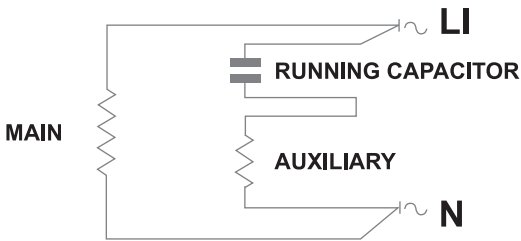

CMLL Series

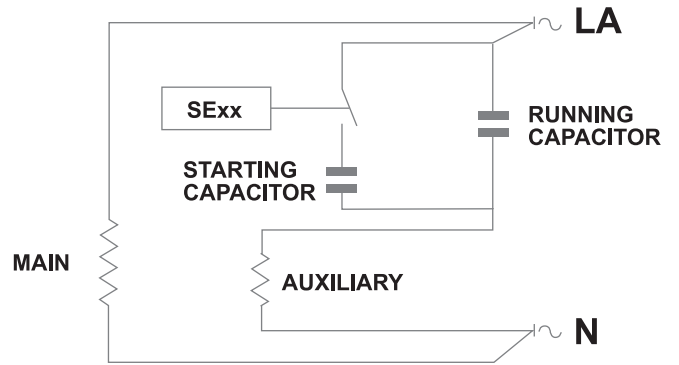

SExx: electronic device for connection of starting capacitor

